

Water Technologies

Water Champ® F Series  
4" Submersible Chemical  
Induction System

Model No. SWC2F

Product Sheet



The Water Champ® Submersible Chemical Induction System is an innovative device designed for the application of a variety of chemicals used for the treatment of potable water and wastewater. The unique feature of the Water Champ® system is its ability to provide instantaneous mixing and diffusion.

The "F" Series submersible offers the highest quality of design and construction of any submersible chemical induction unit. The hermetically sealed 316 SS motor offers the highest level of durability and performance required for chemical feed applications. Most wetted materials are constructed from Grade 2 Titanium (unalloyed) and are designed for use with most treatment chemicals. The innovative mounting is configured for mounting in open-channel applications and can

Features:

- Titanium Wetted Parts\*
- Rugged Construction
- Heavy Duty Bearing Design

Specifications:

Model No.	HP (KW)	Maximum Gas Induction CL <sup>2</sup> PPD (kg/d)	Maximum Liquid Induction GPM (l/min)	Maximum Vacuum (in. Hg) (kPa)
SWC2F	2 (1.5)	500* (226.8)	15* (56.8)	18 (.61)

\*Feed rates are application dependent (Consult factory)

Benefits of the Water Champ® F Series System include:

- Instantaneous diffusion and mixing
- Energy and chemical savings
- Maximum chemical concentration with no off-gassing
- Warranty—1 year from start-up or 18 months after delivery whichever occurs first

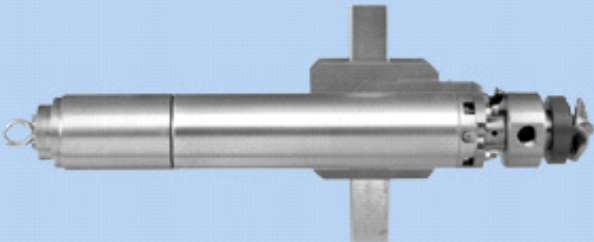

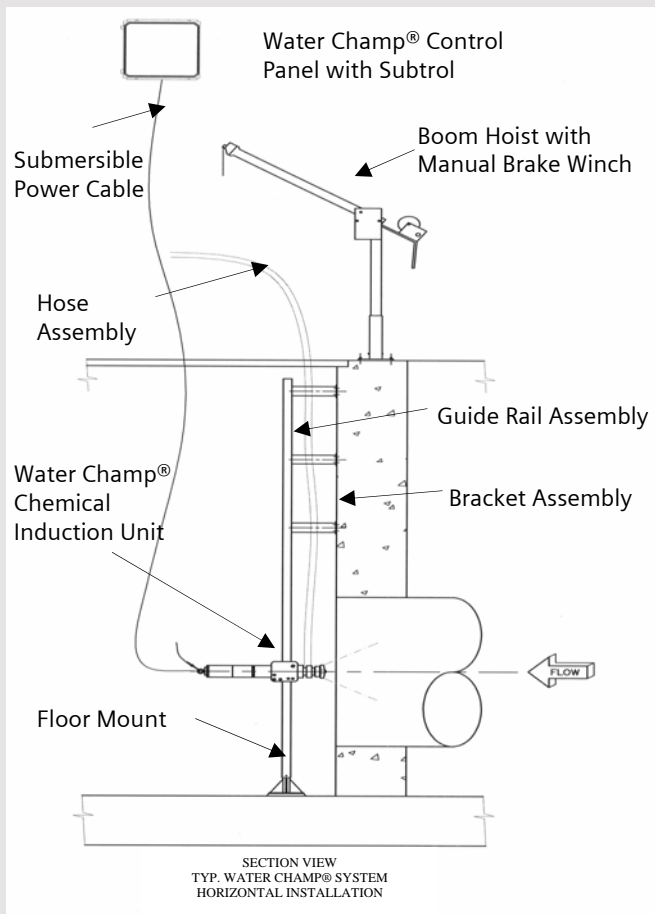

Part	Material
Vacuum Chamber	Titanium
Vacuum Port	Titanium
Vacuum Enhancer	Non-Metallic
Propeller	Titanium
Propeller Bolt	Titanium
Shaft	Titanium
Mechanical Seal	Carbon / Ceramic
Motor	316 Stainless Steel
Power Cable	TC Type (25 feet standard)
Hardware	316 Stainless Steel

### Motor Performance Data

Model	HP (KW)	Volts	Phase	Hertz	RPM	Insulation	S.F.	Rated Input Amps	Max. Input Amps	Locked Rotor Amps	Power Factor %			Efficiency %		
											S.F.	F.L.	3/4	S.F.	F.L.	3/4
SWC2F	2 (1.5)	200	3	60	3450	Class B	1.25	7.7	9.3	53.6	84.4	79.0	71.2	69.5	69.5	67.4
SWC2F	2 (1.5)	230	3	60	3450	Class B	1.25	6.7	8.1	46.6	84.4	79.0	71.2	69.5	69.5	67.4
SWC2F	2 (1.5)	230	1	60	3450	Class B	1.25	Y10.0 B9.3 R2.6	Y13.2 B11.9 R2.6	51.0	93.1	90.5	86.7	70.0	71.0	68.8
SWC2F	2 (1.5)	460	3	60	3450	Class B	1.25	3.4	4.1	23.3	84.4	79.0	71.2	69.5	69.5	67.4
SWC2F	2 (1.5)	575	3	60	3450	Class B	1.25	2.7	3.2	18.6	84.4	79.0	71.2	69.5	69.5	67.4

Water Champ is a trademark of Siemens, its subsidiaries or affiliates.

The information provided in this brochure contains merely general descriptions or characteristics of performance which in actual case of use do not always apply as described or which may change as a result of further development of the products. An obligation to provide the respective characteristics shall only exist if expressly agreed in the terms of the contract.

Siemens  
Water Technologies  
595 Industrial Drive  
Bradley, IL 60915, USA  
800.809.0971 phone  
www.usfilter.com  
stranco.water@siemens.com

Literature No. ST-SWC2F4-DS-0806  
Subject to change without notice.  
©2006 Siemens Water Technologies Corp.