

Membrane Pumps
Solids Handling Pumps
High Pressure Pumps
Marine Pumps

ABEL HM

Hydraulic Membrane Pumps
Low Energy Consumption



Highly Efficient, Reliable, and Dependable

ABEL[®]
Pump Technology

ABEL HM Hydraulic Membrane Pumps Capacity up to 500 US GPM, Pressure up to 1450 PSI

Versatile modular construction

Optimum membrane performance

ABEL HM in action for

- Filter press feed
- Sludge transfer
- Spray dryer feeding
- Furnace feeding
- Metering

Markets:

- Water and wastewater industries
- Ceramic industry
- Mining industry
- Cement industry
- Chemical and petrochemical Industry
- Automobile industry

Wet-end construction:

- Nodular cast iron
- Nodular cast iron/rubber lined
- Stainless steel
- Polypropylene (PPH)
- Other materials on request

ABEL Hydraulic Membrane Pumps are equipped with newly designed, preformed membrane and pressure-balanced membrane positioning. During the suction as well as the pressure stroke the membranes are not loaded with pressure peaks; This ensures membrane positioning with optimal membrane end positions.

Single or double acting

ABEL HM is available in simplex single or double-acting design. In addition to the attributes of piston membrane pumps such as self-priming and dry running resistance, the pumps are characterized by high efficiency, quiet running and availability.

Design advantages side by side

The hydraulic side is equipped with tested safety valves to safeguard the maximum allowable pressure. The product side is equipped with a preformed membrane adapted to the operating conditions. The drive side, consisting of the reduction and eccentric gear, ensures an optimum power transmission even at lower speed – and all that without external oil lubrication.

A significant reduction of the energy costs is achieved by using frequency converters in filter press operation. No heating and thus, no energy losses, occur on the hydraulic side of the pump.

The ABEL HM are controllable in compliance with the present technical status.

Energy Reduction by Control:

Example Filter Press

Control:

- Filtration cycle 1,5 h
- Energy consumption:
 - conventional 7,08 kWh
 - HM-Pump 4,46 kWh
- **Energy saving: 2,62 kWh or approx. 37%**

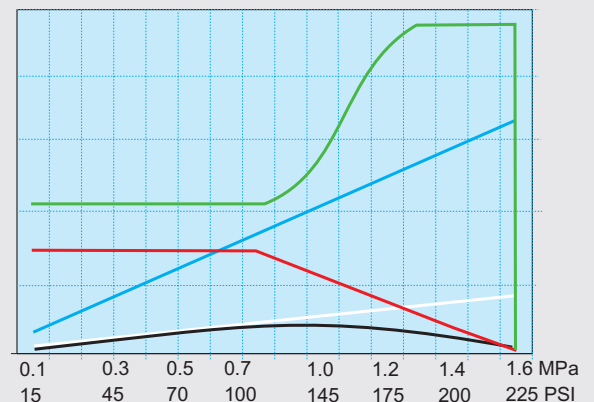
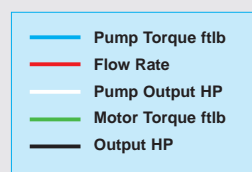

Hydraulic Membrane Pumps HM Series

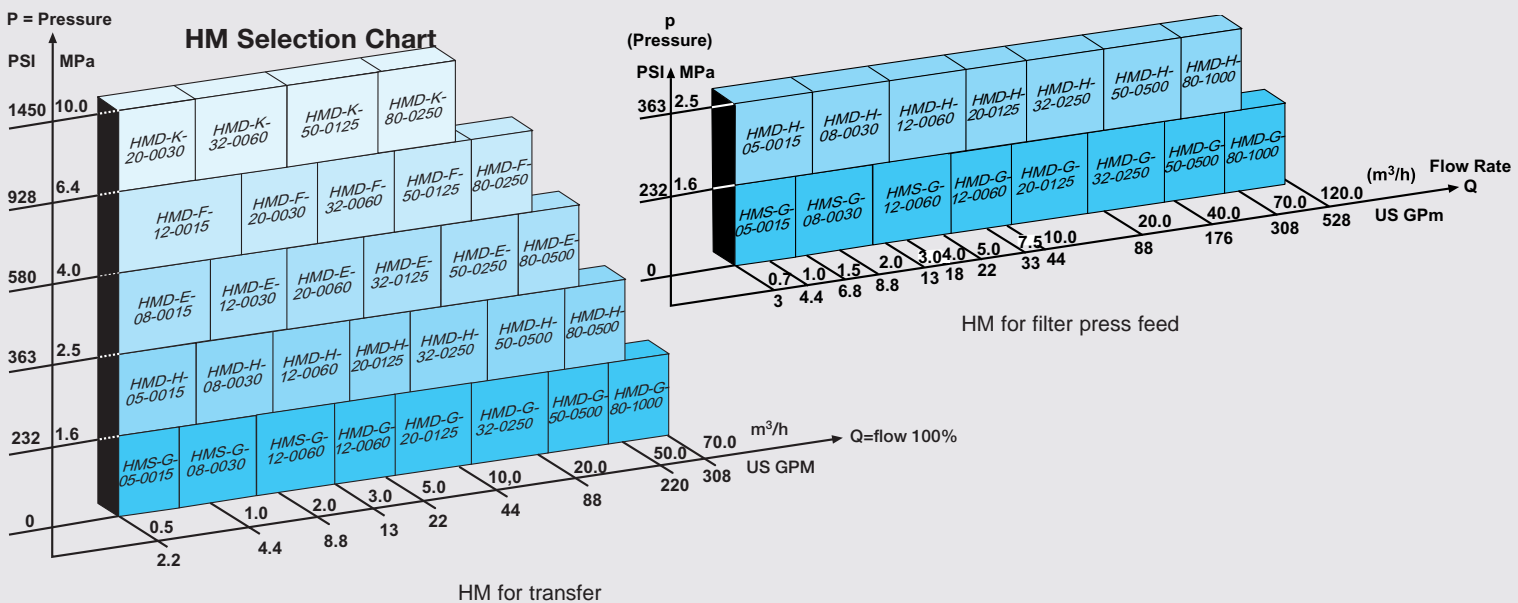

Positive Membrane Positioning

Durable under pressure

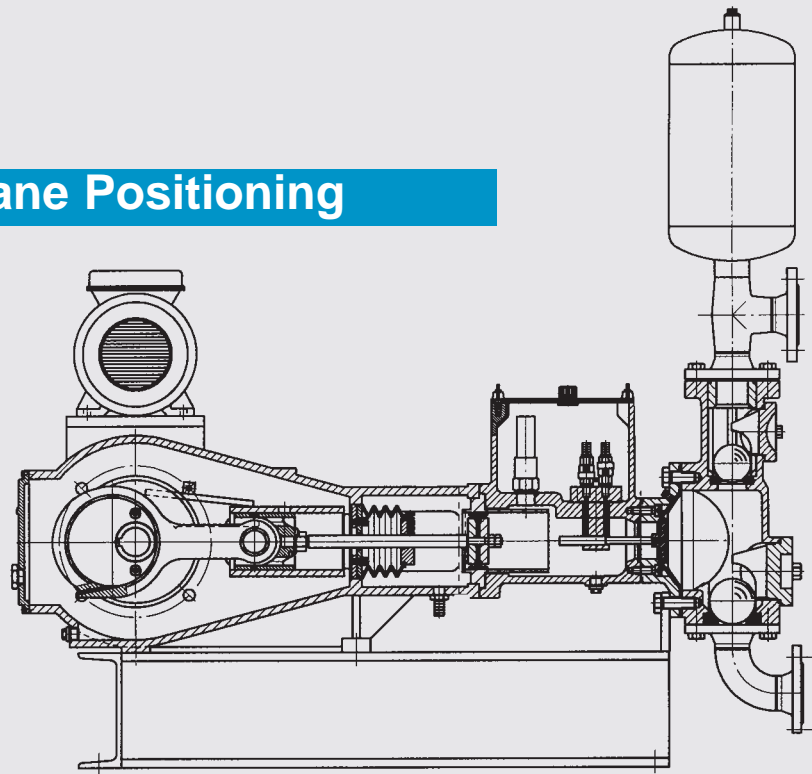

Single-acting design

Through V-belt, external transmission gear and eccentric gear the motor speed is converted into a reciprocating piston movement. The stroke volume displaced by the piston deflects the membranes.

During the suction and pressure stroke the membrane positioning system monitors the controlled movement of the membranes.

ABEL HM pumps are available in single or double-acting design depending upon pump capacity.

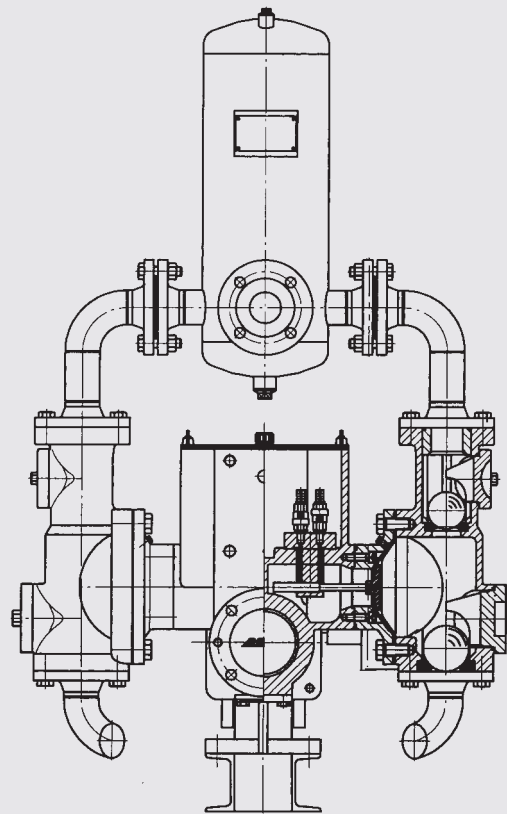

Double-acting design



ABEL HM
 Hydraulic Membrane Pumps
 Low Energy Consumption

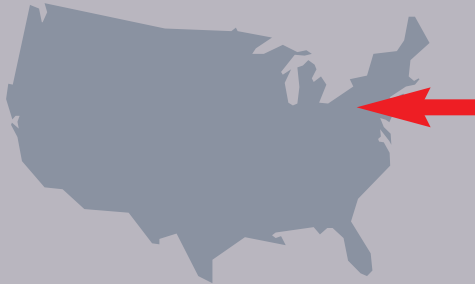

ABEL Pumps, L.P.
 79 N. Industrial Park
 207 Overlook Dr
 Sewickley, Pennsylvania
 PA 15143-2339 USA
 Tel: 412 741 3222
 Fax: 412 741 2599
 mail@abelpumps.com
 www.abelpumps.com

Assistance:

The qualified staff of ABEL Pumps, L.P. is ready to assist you with your critical needs.

Please contact us with your specific requirements.

Services include:

- ▲ Start-up
- ▲ Training
- ▲ Installation
- ▲ Repair
- ▲ Warranty Contracts
- ▲ Upgrades
- ▲ Telephone Diagnostics
- ▲ On Site Repairs
- ▲ Part Kits
- ▲ Qualified Representatives for Local Assistance

Certifications:

- ▲ ISO 9001
- ▲ MIL-I-45208A Inspection Compliant

Helpful Information:

Company:	e-mail:
Address:	Tel./Fax:
	Contact:
Application:	Why needed?
	Temperature:
Fluid:	Sp. Gr.:
Flow Rate:	Pressure:
Solids? % & size:	Viscosity:
Operating Cycle:	Special Materials:

Combined Slurry:

% Solids 1) By Weight 2) By volume

Abrasivity (Miller Number) PH Value

Viscosity Describe consistency

Remarks:

Thank you for the opportunity to be of service! – ABEL Pumps, L.P.